



Submittal/ Specification Data Sheet

The BaySaver[®] Separation System

The **BaySaver[®] Separation System** is a stormwater treatment BMP used to remove total suspended solids (TSS), free floating oils and debris.

It consists of (2) standard precast manholes, (1) BaySaver unit constructed of high density polyethylene containing black carbon for UV resistance, (2) Fernco couplers, (2) Mar Mac polyseal couplers, (2) connection pipes and an HDPE reducer/adaptor.

Product Benefits

- The BaySaver System will treat at an 80% or higher efficiency rate for TSS removal
- Treats the entire storm, not just the first flush
- Off line storage eliminates resuspension of pollutants
- Does not require green space
- Easy one day installation
- Inspection and maintenance without confined space entry
- Meets ASHTO H-20 requirements

Manhole Sizing

BaySaver Separation Systems use identically sized structures for both the primary and storage manholes (see Table 1). The designer can choose to use larger manholes to account for factors specific to the site such as a need for increased pollutant storage. The additional sediment and oil storage capacity will result in a longer interval between required maintenance procedures.

Table 1: BaySaver Separation System standard manhole sizing guidelines

Specify Unit here	BaySaver Unit Model	Maximum Treatment Flow (cfs)	Primary Manhole Diameter (inches)	Storage Manhole Diameter (inches)
	1/2K	1.1	48	48
	1K	2.4	48	48
	3K	7.8	60	60
	5K	11.1	72	72
	10K	21.8	120	120

Storage Capacities

BaySaver Systems retain the trapped pollutants in the two precast manholes. Maintenance is required when the accumulated sediments in either manhole reach a height of two feet from the floor. The maintenance interval for a typical installation is determined by the sediment buildup; on most sites, oils and floatables will not accumulate at the same rate as solids.

Table 2: BaySaver System storage capacities

Model/System Size	Total System Volume (gallons (ft ³))	Sediment Capacity (yards ³ (ft ³))	Floatable Capacity (gallons (ft ³))
1/2K 48 X 48	1475 (200)	1.86 (50)	280 (37)
1K 48 X 48	1475 (200)	1.86 (50)	280 (37)
3K 60 X 60	2325 (310)	2.90 (78)	430 (58)
5K 72 X 72	3350 (450)	4.18 (113)	630 (84)
10K 120 X 120	5950 (800)	7.44 (201)	1110 (150)

Treatment Flow Rates

The best way to size the BaySaver System is to calculate the flow rate that will be conveyed through the system. In this way it can be determined which separator unit meets site specific design capacities and local regulations (see Table 3).

Table 3: BaySaver Separator unit flow rates

Specify Unit Here	BaySaver Model Number	Maximum Treatment Flow (cfs/gpm)	Peak design Flow (cfs/gpm)	Head Loss (inches)
	1/2K	1.1 / 494.0	8.5 / 3815	6.3
	1K	2.4 / 1076.4	10 / 4485	5
	3K	7.8 / 3498.4	30 / 13455	6
	5K	11.1 / 4978.3	50 / 22425	12
	10K	21.8 / 9777.3	100 / 44850	12

Questions

Please call toll free **(800)229-7283** or visit our web site at www.baysaver.com

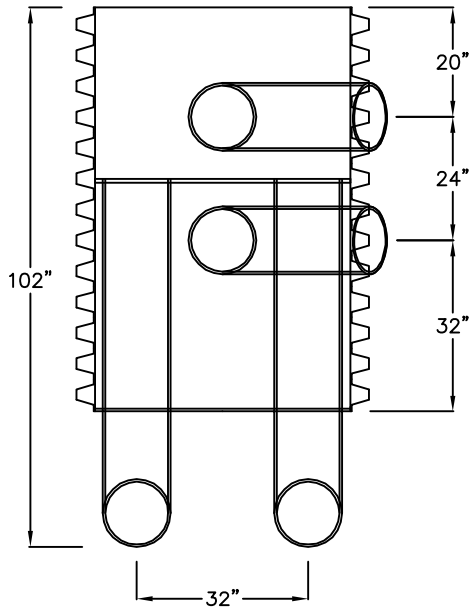

FABRICATION NOTES:

1. SEPARATOR UNIT SHALL BE CONSTRUCTED ENTIRELY OF HIGH DENSITY POLYETHYLENE. HDPE MATERIAL SHALL CONTAIN CARBON-BLACK TO PROVIDE UV RESISTANCE.
2. ALL JOINTS SHALL BE WELDED BY EXTRUSION WELDING OR BUTT-FUSION WELDING. BUTT-FUSED JOINTS SHALL BE REINFORCED BY AN EXTRUDED BEAD AROUND THE FUSION AREA.
3. SOLID WALL HDPE PIPE SHALL BE MINIMUM SDR-26.
4. HDPE PLATE SHALL BE 3/4" THICKNESS.

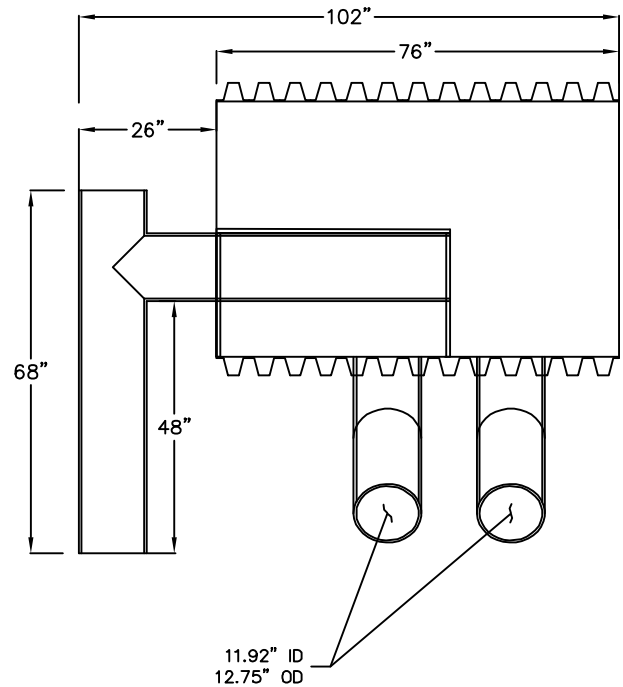
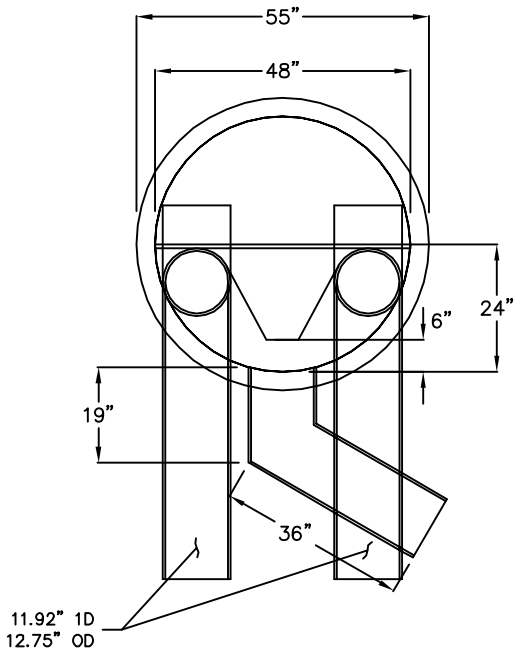

BAYSAVER®

1302 RISING RIDGE ROAD UNIT 1
MOUNT AIRY, MD 21771
(301) 829-6470

DESIGNED:	TEP
DRAWN:	TFR
CHECKED:	ATM
DATE:	12/06/02
SCALE:	1" = 36"
SHEET:	1 OF 2

5K SEPARATOR UNIT

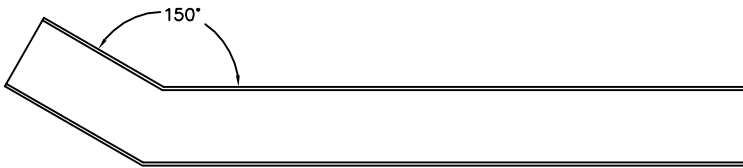

HDPE CONNECTION PIPES

FOR CONNECTION TO STORAGE MANHOLE
NOT TO SCALE

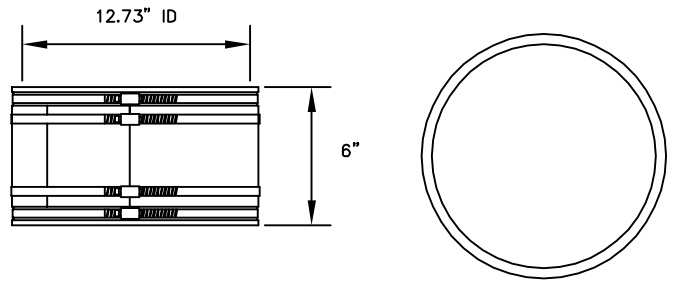

FERNCO FITTING DETAIL

(NOT TO SCALE)
FERNCO PART # 1004-1010
SHEAR RING PART # SR-44

HDPE-HDPE REDUCER DETAIL

FOR USE WITH HDPE OUTLET PIPES
NOT TO SCALE

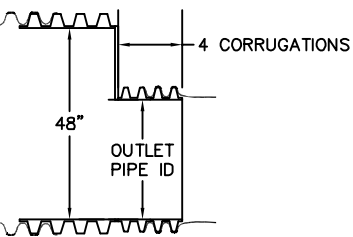
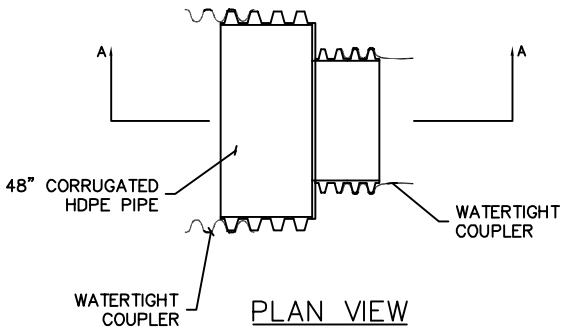

SECTION AA

BAYSAVER®

1302 RISING RIDGE ROAD UNIT 1

MOUNT AIRY, MD 21771

(301) 829-6470

DESIGNED:	TEP
DRAWN:	TFR
CHECKED:	ATM
DATE:	10/17/02
SCALE:	N.T.S.
SHEET:	2 OF 2

5K SEPARATOR UNIT
NOTES AND DETAILS

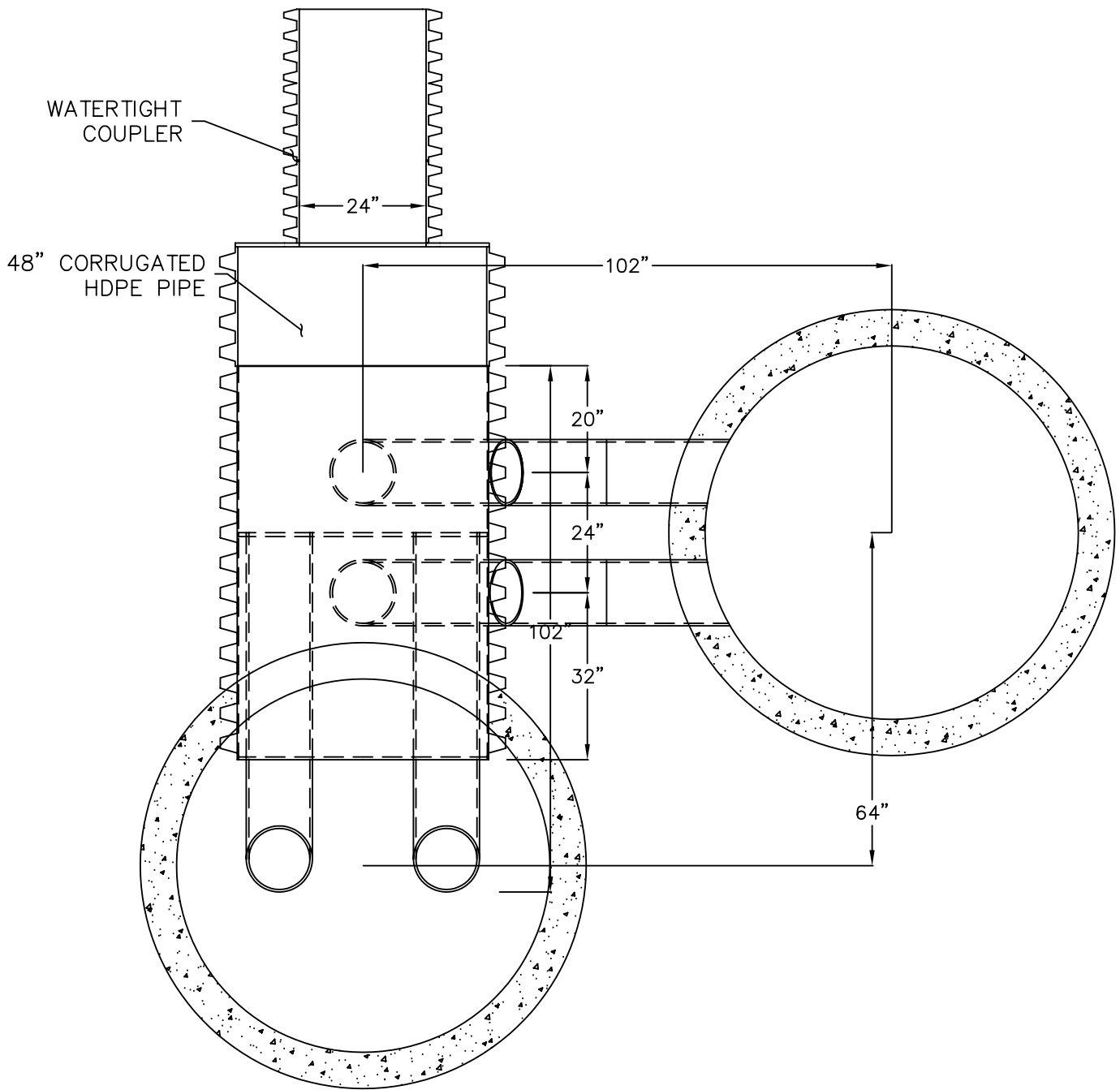

BAYSAVER®

1302 RISING RIDGE ROAD UNIT 1
 MOUNT AIRY, MD 21771
 (301) 829-6470

DESIGNED:	TEP
DRAWN:	SNW
CHECKED:	ATM
DATE:	8/8/03
SCALE:	N.T.S
SHEET:	1 OF 1

5K SEPARATOR UNIT
 LAYOUT 72X72

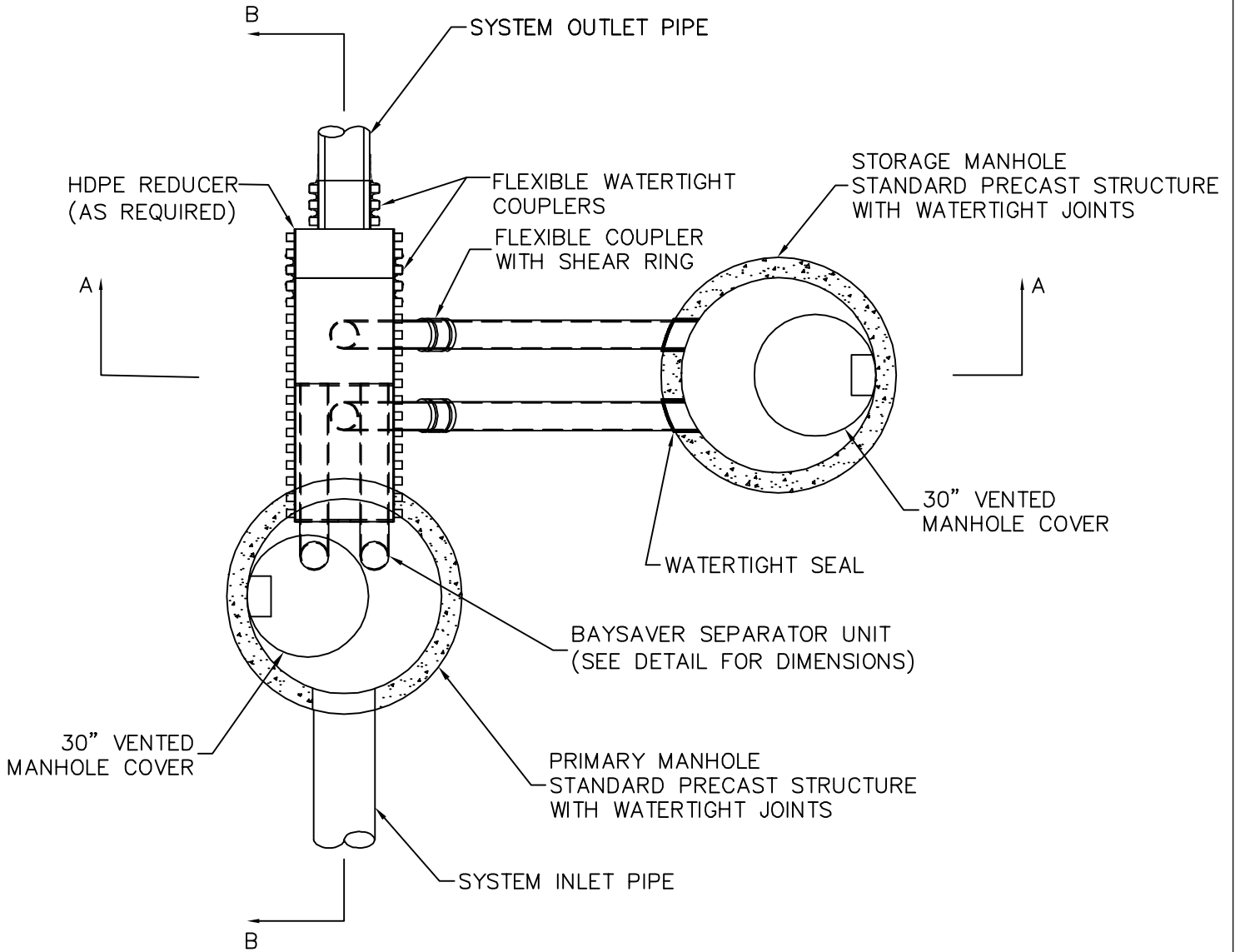

BAYSAVER®

1302 RISING RIDGE ROAD UNIT 1
 MOUNT AIRY, MD 21771
 (301) 829-6470

DESIGNED:	TEP
DRAWN:	TFR
CHECKED:	ATM
DATE:	10/18/02
SCALE:	N.T.S.
SHEET:	1 OF 3

BAYSAVER SEPARATION
 SYSTEM PLAN VIEW

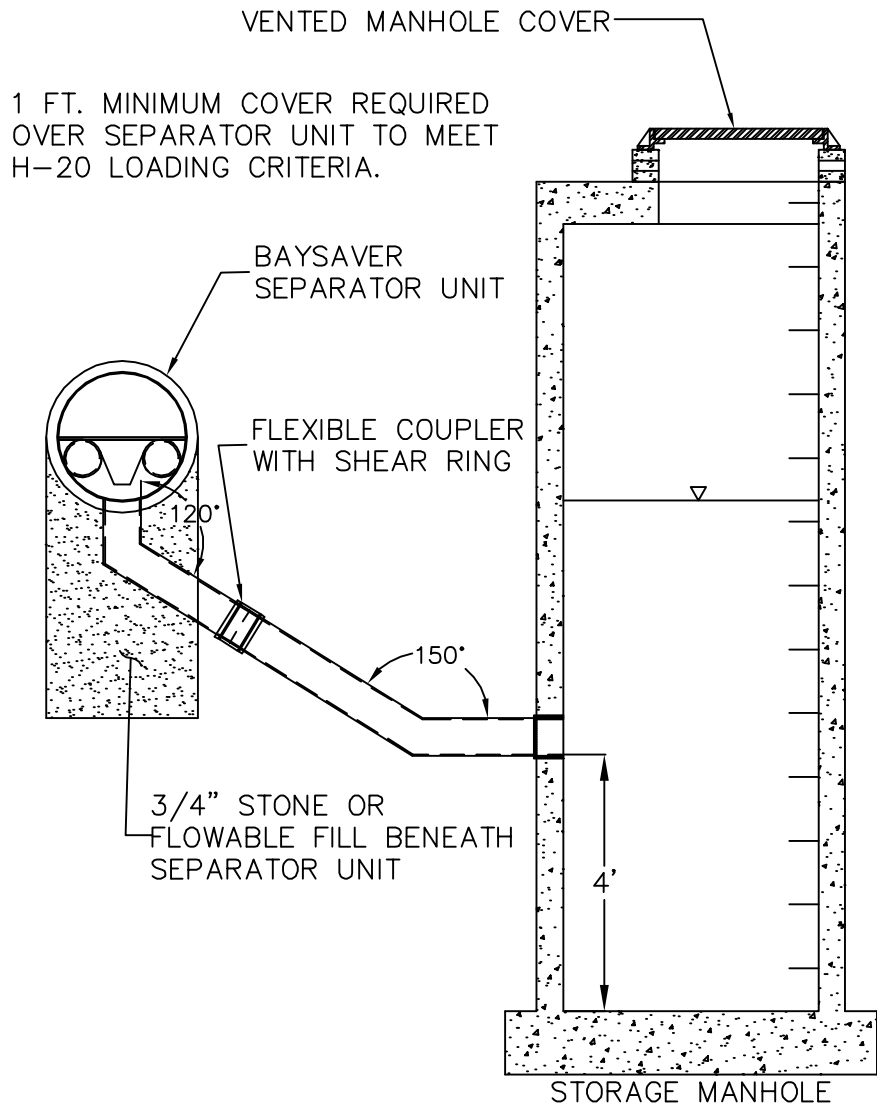

SECTION AA

BAYSAVER®

1302 RISING RIDGE ROAD UNIT 1

MOUNT AIRY, MD 21771

(301) 829-6470

DESIGNED:	TEP
DRAWN:	TFR
CHECKED:	ATM
DATE:	10/18/02
SCALE:	N. T. S.
SHEET:	2 OF 3

BAYSAVER SYSTEM
SECTION A-A

1 FT. MINIMUM COVER REQUIRED OVER SEPARATOR UNIT TO MEET H-20 LOADING CRITERIA.

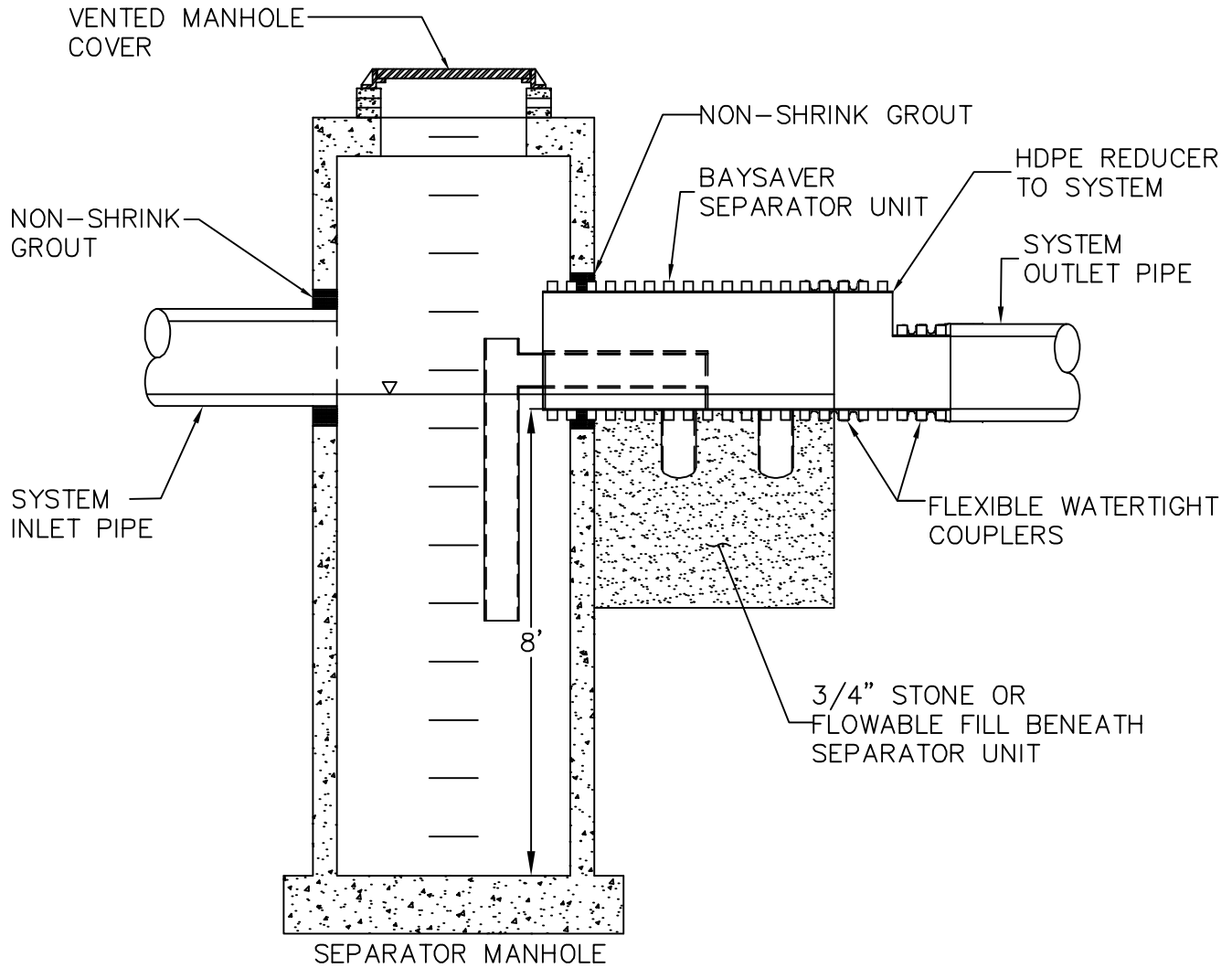

SECTION BB

BAYSAVER®

1302 RISING RIDGE ROAD UNIT 1
MOUNT AIRY, MD 21771
(301) 829-6470

DESIGNED:	TEP
DRAWN:	TFR
CHECKED:	ATM
DATE:	10/18/02
SCALE:	N.T.S.
SHEET:	3 OF 3

BAYSAVER SYSTEM
SECTION B-B

BaySaver Separation System

INSTALLATION INSTRUCTIONS

1.0 EXCAVATION AND INSTALLATION

- 1.1 Call local utility locator to make certain it is safe to excavate.
- 1.2 Determine the location of the separator and storage structures and excavate the hole. Excavation must provide adequate space to connect inlet and outlet pipes to the storage manhole and the BaySaver unit.
- 1.3 Verify the sub grade elevation against the manhole dimensions and connecting storm drain inverts. Adjust base aggregate if necessary.
- 1.4 Install the primary separation manhole and secondary storage manhole on solid sub grade. Make sure the bases are level and the storage manhole openings are aligned with the separator unit. Install rubber gaskets on base units and coat with lubricating grease. Install additional manhole sections as required.
- 1.5 Seal all lift holes according to applicable regulations.

2.0 BACKFILL & COMPLETION

- 2.1 Backfill base sections of manholes to invert of storage manhole connecting pipe using an acceptable backfill material. Backfill and compact in lifts to allow for proper compaction
- 2.2 Install BaySaver Separator Unit and connecting pipes. Seal all connecting joints and install separator unit/ storm drain joint collar. Provide temporary supports and hold-downs as necessary to stabilize unit during remaining backfill operation.
- 2.3 Backfill separator unit and manholes. Areas not accessible to compaction equipment must be backfilled with some stone or flowable fill.
- 2.4 Install and set manhole frame and cover units and make grade adjustments as necessary.
- 2.5 Fill structures with water
- 2.6 The separation manhole and the storage manhole shall be pumped out when sediment control measures are removed and the site is permanently stabilized. Sediment and debris must be disposed of properly